



R. K. Casting & Engineering Works
PVT. LTD.

Casting & Machining works

CUSTOMER SATISFACTION

2020

Flexible Gear Couplings - F Series



Address :- Near By BCCL Moonidih -
Washri Road, Moonidih - 828 129,
Dhanbad, Jharkhand, India

Mail Id - info@rkcasting.com



SERIES F

WITH R. K. CASTING & ENGINEERING WORKS TOOTH FORM FOR LONG LIFE
 Maximum torque: up to 5 040 000 Nm ,, Bore: up to 1 130 mm

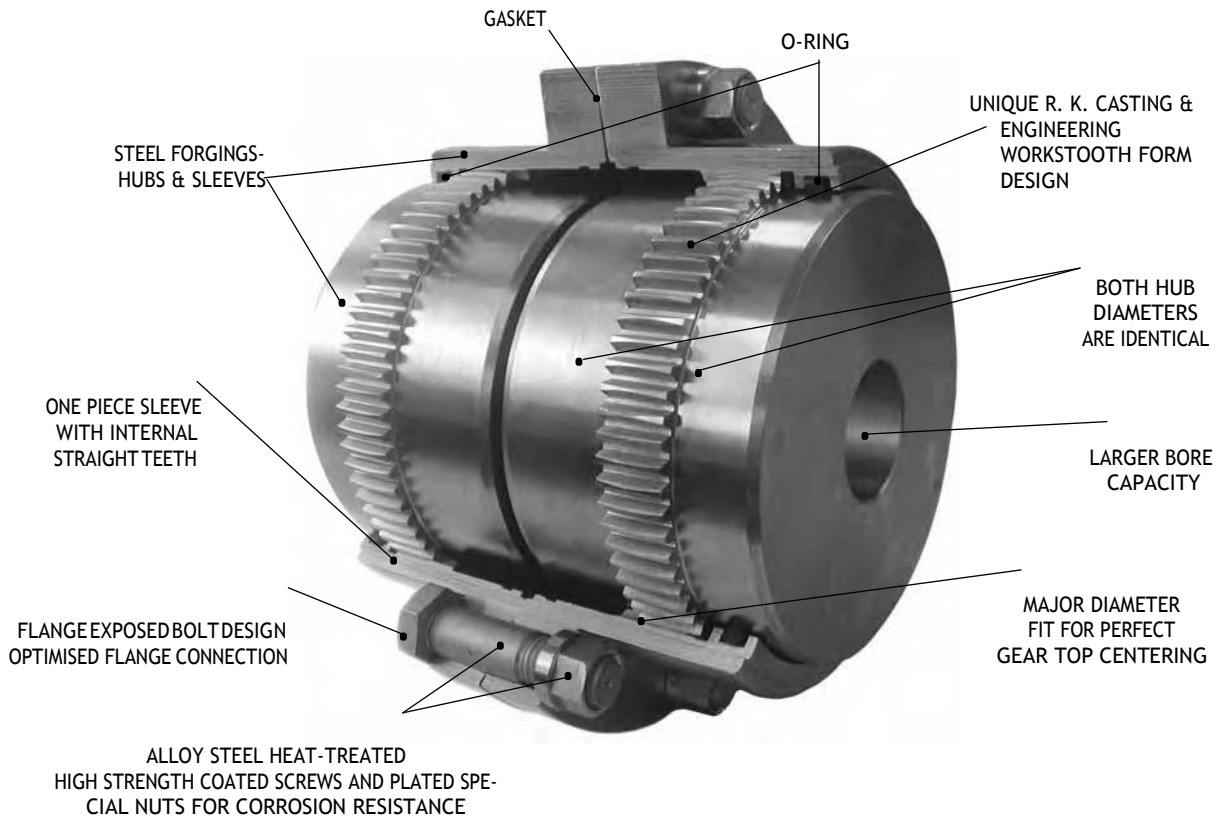

LOWER STRESSES

The **R. K. CASTING & ENGINEERING WORKS** tooth form is a curve with constantly changing radii of curvature. The tooth contact area under misaligned conditions has a much larger radius of curvature than conventional crowning. The contact area therefore is larger thus reducing the surface stresses.

CONSTANT VELOCITY POWER TRANSMISSION

ESCO generates the **R. K. CASTING & ENGINEERING WORKS** tooth in such a way that the necessary characteristics for homocentric conjugate tooth action are perfectly achieved.





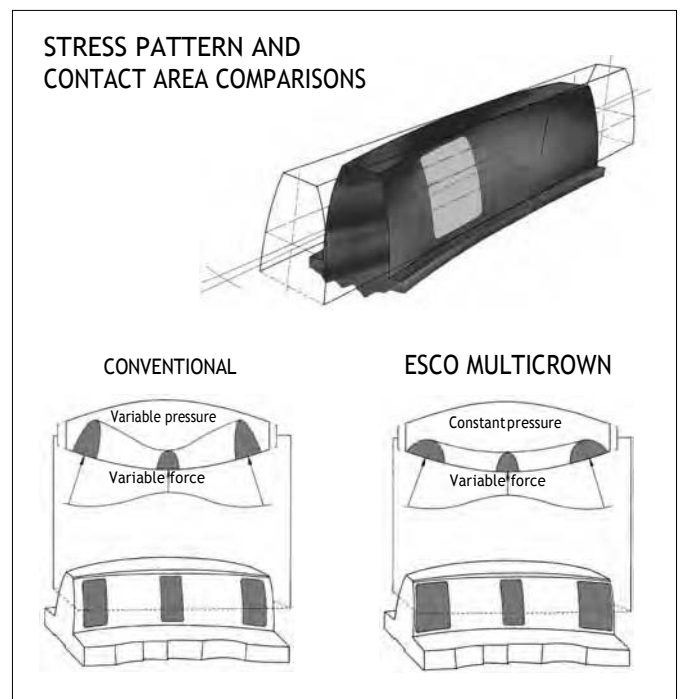





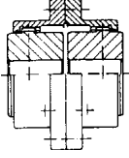

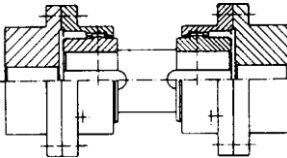
LESS BACKLASH

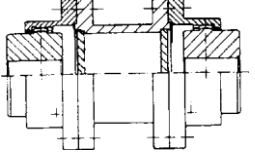

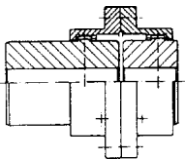

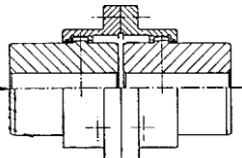

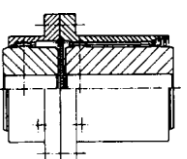

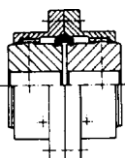

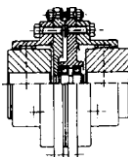
The **R. K. CASTING & ENGINEERING WORKS** tooth design requires less backlash for a given angle of misalignment than the conventional crowning, thus reducing shocks in reversing application.

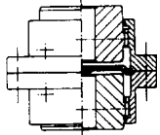

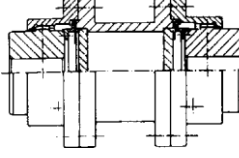

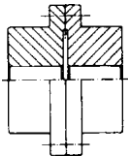
AVAILABILITIES

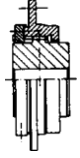
FST	 * B410 & B411	
STANDARD		
FFS	 * B412	
FLOATING SHAFT		
FSE	 * B413	
SPACER EXECUTION		
FMM	 * B414	
MILL-MOTOR		
FDMM	 * B415	
DOUBLE MILL-MOTOR		
FSH	 * B416	
SLIDING HUB		
FLE	 * B417	
LIMITED ENFLOAT		

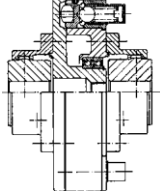
Bolts and nuts (metric)		Bolts and nuts (conform to AGMA 516.01)
Exposed metric "EM"		Exposed inch "EI"
FSP	 * B418	
SHEAR PIN		
FSV	 * B419	
STANDARD VERTICAL		
FSLE	 * B420	
LIMITED ENDFLOAT		
FRR	 * B421	
RIGID-RIGID		
FWD	 * B422	
WINCHDRUM		
FET	 * B423	
WITH ESCOTORQUE		



OTHER TYPES AVAILABLE (on request)

<p>FDSH DOUBLE SLIDING-HUB</p>		<p>FBD WITH BRAKE DISC</p>	
<p>FFSV VERTICAL FLOATING-SHAFT</p>		<p>FBP WITH BRAKE-PULLEY</p>	
<p>FIN INSULATED</p>		<p>FCO CUT-OUT</p>	
<p>FFA TO BE ADAPTED ON FLYWHEEL OR FLANGE</p>		<p>FSESP SHEAR SPACER</p>	

Only a few special types of couplings are illustrated. Additional special types are available on request.

SHAFT CONNECTIONS

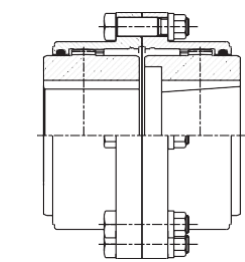

KEYWAY

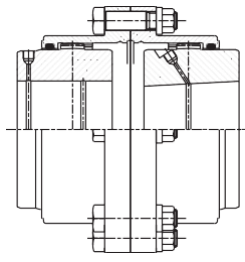

INTERFERENCE FIT

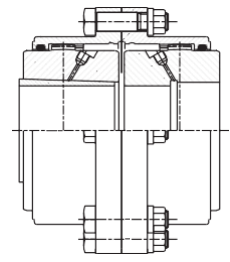

INTERFERENCE WITH
INTERMEDIATE CONICAL BUSHING

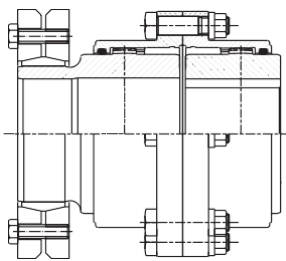

EXTERNAL CLAMPING

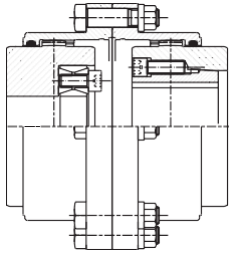

INTERNAL CLAMPING

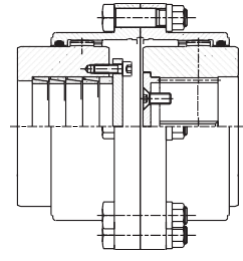

SPLINES



HOW TO SELECT THE RIGHT COUPLING SIZE

A. Select the size of ESCOGEAR coupling that will accommodate the largest shaft diameter.

B. Make sure this coupling has the required torque capacity according to following formula: $\text{torque in Nm} = \frac{9550 \times P \times F_u \times F_{i_{1x}}}{n}$

P = power in kW; n = speed in rpm; F_u = service factor according to tabulation 1.

$F_{i_{1x}} = 2$ in case of use in potentially explosive atmospheres i_{1x} , European Directive 94/9/EC. In normal atmospheres, $F_{i_{1x}} = 1$.

The coupling selected per **(A)** must have an equal or greater torque capacity than the result of the formula **(B)**. If not select a larger size coupling. Check if application peak torque does not exceed tabulated peak torque T_p indicated planographs B410 to B423.

Check also max. allowable misalignment using the graph of tabulation 2.

C. Check if shaft/hub connection will transmit the torque. If necessary, select a longer hub.

D. Read carefully assembly and maintenance instructions IM/B400.

TABULATION 1		APPLICATIONS	DRIVER MACHINE		
			Electric motors Turbines	Hydraulic motors Gears drivers	Reciprocating engine Electric motors frequent starts
DRIVEN MACHINE	UNIFORM	Generators - Blowers: centrifugal vane, fans - Centrifugal pumps and compressors - Machine tools: auxiliary drives - Conveyors: belt and chain, uniformly loaded, escalators - Can filling machines and bottling machinery - Agitators: pure liquids.	0,8 to 1,25	1 to 1,5	1,25 to 1,75
		Propeller - Waterjet pumps	1,25	1,5	1,75
	MODERATE SHOCKS	Blowers: lobe - Pumps: gear and lobe types - Vane compressors - Machine tools: main drives - Conveyors: belt and chain not uniformly fed bucket and screw - Elevators, cranes, tackles and winches - Wire winding machines, reels, winders (paper industry) - Agitators liquids and solids, liquids variable density.	1,25 to 1,5	1,5 to 1,75	1,75 to 2
HEAVY SHOCKS	Generators (welding) - Reciprocating pumps and compressors - Laundry washers - Bending roll, punch press, tapping machines - Barkers, calanders, paper presses - Briquetter machines, cement furnace - Crushers: ore and stone, hammer mill, rubber mill - Metal mills: forming machines, table conveyors - Draw Bench, wire drawing and flattening machines - Road & railroad equipment.	1,5 to 2	1,75 to 2,25	2 to 2,5	

1) MAXIMUM MISALIGNMENT

TABULATION 2

GRAPH (T, n)

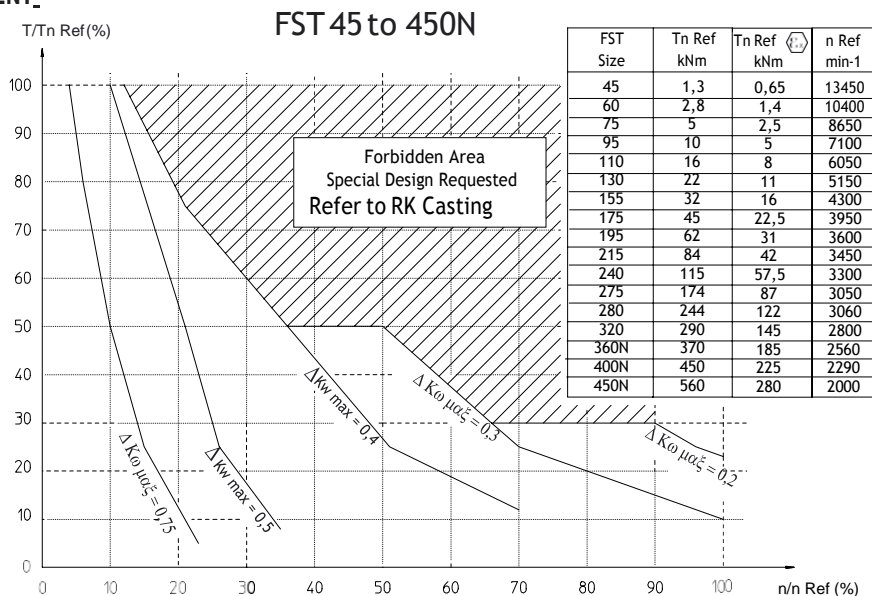

HOW TO USE THE GRAPH (T, n)?

Maximum torque, maximum speed and maximum misalignment may not occur simultaneously.

Graph must be used as follows:

1. Calculate T_n and T_p and select coupling size as usual. T_n = nominal torque; T_p = peak torque
2. Calculate $T_n/T_n\text{Ref}$ and $n/n\text{Ref}$ and plot the resulting point in the graph.
3. If the resulting point is located in the white area, a standard coupling may be used as far as maximum misalignment doesn't exceed the maximum misalignment indicated in the graph.
4. If the resulting point is located in the shaded area, refer to R. K. Casting & Engineering Works
5. In case of use in potentially explosive atmospheres i_{1x} proceed the same way but using $T_n\text{Ref}(i_{1x})$ for the calculation. Max misalignment may not exceed $0,5^\circ$ per gear mesh.



2) MINIMUM MISALIGNMENT = $\Delta K_{wmin} = 0,1^\circ$

3) MISALIGNMENT CONTROL

1- Measure X (TIR) - 2- Measure Y-Z - 3- Verify the relationship for the misalignment control: $\Delta K_{wmin} \leq \frac{X}{K_x} + \frac{Y-Z}{K_y} \leq 0,75 \times \Delta K_{wmax}$

$K_x = K_{x0} + \frac{S}{30}$ with S = Spacer length (mm)

(If no spacer: S=0)

$K_y = K_{y0}$

FST	K_{x0}	K_{y0}
45	1,92	2,34
60	2,06	3,04
75	2,76	3,71
95	3,25	4,54
110	3,80	5,28
130	4,47	6,22
155	5,03	7,55
175	5,72	8,20
195	6,35	9,18
215	7,47	9,98
240	8,24	11,04
275	9,18	12,98
280	10,82	13,76
320	11,34	15,08
360	12,32	16,76
400	13,37	18,50
450	14,35	20,74

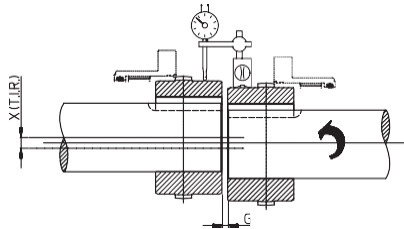
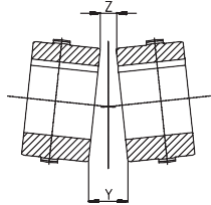

4) EXAMPLES:

Calculation

$T/T_{nref} = 30^{a/n}$
 $n/n_{ref} = 30^{a/n}$ } $\Delta K_{wmax} = 0,4^\circ$

FST 175: $K_x = 5,72$ $K_y = 8,2$

Measurement

X (TIR) = 0,9 mm Y-Z = 0,4 mm

Control

Formule:

$\Delta K_{wmin} \leq \frac{X}{K_x} + \frac{Y-Z}{K_y} \leq 0,75 \times \Delta K_{wmax}$

Calculation: $0,1^\circ \leq \frac{0,9}{5,7} + \frac{0,4}{8,2} \leq 0,75 \times 0,4$ ok

LEGEND OF USED PICTOGRAMS		Notes for series F	
	MAXIMUM NOMINAL BORE (mm) MINIMUM BORE (mm) MAXIMUM BORE (mm)	<ol style="list-style-type: none"> 1 For key according to ISO R 773. 2 Gear maximum continuous transmissible torque for the tabulated misalignment. The effective transmissible torque depends on the bore and shaft/hub connection. 3 Higher speed on special request. 3.1 For grease withstanding centrifugal acceleration of 1.000g. See installation and maintenance manual IM. 3.2 For grease withstanding centrifugal acceleration of 2.000g. See installation and maintenance manual IM. 3.3 Depends on S. 3.4 For long operation in disconnected position contact us. 4 For solid bore. 4.1 Depends on S. 4.2 For solid bore and S minimum. 4.3 Per 100 mm spacer length. 4.4 Depends on L and R. 5 For pilot bored hubs. 5.1 Depends on S. 5.2 For pilot bored hubs and S minimum. 5.3 Per 100 mm spacer length. 5.4 Depends on L and R. 6 See installation and maintenance manual IM. 6.1 Depends on S. Values given for S maximum. 7 On request. For larger S contact us. 8 Values for S minimum. S maximum depends on torque and speed. 9 G must remain constant during operation. 10 Needed to control the alignment and inspect the gears. 	
	MAXIMUM NOMINAL TORQUE (Nm) MAXIMUM PEAK TORQUE (Nm)		
	MAXIMUM SPEED (rpm)		
	MAXIMUM OFFSET (mm)		
	MAXIMUM ANGULAR MISALIGNMENT (degree)		
	INERTIA (kgm²)		
	WEIGHT (kg)		
	GREASE QUANTITY (dm³)		
			<p>*Max. torque, speed and misalignment tabulated values may not be cumulated See IM/B400.</p>



R. K. Casting & Engineering Works
 Equivalence chart based on torque ratings

Torque Capacity (Nm)	Escogear FST (2 x 0,75°)	Flender Zapex (2 x 0,5°)	Maina GO-A (2 x 0,5°)	Jaure MT Series (2 x 0,5°)	Falk Lifelign (2 x 0,5°)	Kopflex Series H
175000						
150000			GO-A 11			
125000	FST 275					
100000	FST 240	ZIN 7	GO-A 10	MT 260	1070G	7H
80000	FST 215	ZIN 6		MT 230	1060G	
60000	FST 195	ZIN 5,5	GO-A9	MT 205	1055G	6H
40000	FST 175	ZIN 5	GO-A 8	MT 185	1050G	5,5H
30000					1045G	5H
20000	FST 155	ZIN 4,5	GO-A 7	MT 165		
15000	FST 130	ZIN 4	GO-A 6	MT 145	1040G	4,5H
10000	FST 110	ZIN 3,5	GO-A 5	MT 125	1035G	4H
7500						3,5H
5000	FST 95	ZIN 3	GO-A 4	MT 100	1030G	3H
3500	FST 75	ZIN 2,5	GO-A 3	MT 90	1025G	2,5H
2500						
2000			GO-A 2	MT 70	1020G	2H
1500	FST 60	ZIN 2	GO-A 1			
1250					1015G	
1000		ZIN 1,5		MT 55		1,5H
750	FST 45		GO-A 0			
500		ZIN 1		MT 42	1010G	1H

Remark: When selecting based upon the above equivalent chart, please check bore capacity of R. K. Casting & Engineering Works. coupling against the application requirements.



ESCO FST	LOVEJOY F	FALK G20, G10	KOP-FLEX H	AMERIDRIVES F	AJAX 6901
45	1	1010	1	101	1
60	1 1/2	1015	1 1/2	101 1/2	1,5
75	2	1020	2	102	2
95	2 1/2	1025	2 1/2	102 1/2	2,5
110	3	1030	3	103	3
130	3 1/2	1035	3 1/2	103 1/2	3,5
155	4	1040	4	104	4
175	4 1/2	1045	4 1/2	104 1/2	4,5
195	5	1050	5	105	5
215	5 1/2	1055	5 1/2	105 1/2	5,5
240	6	1060	6	106	6
275	7	1070	7	107	7



Cement kiln mill drive



Vertical mixer drive

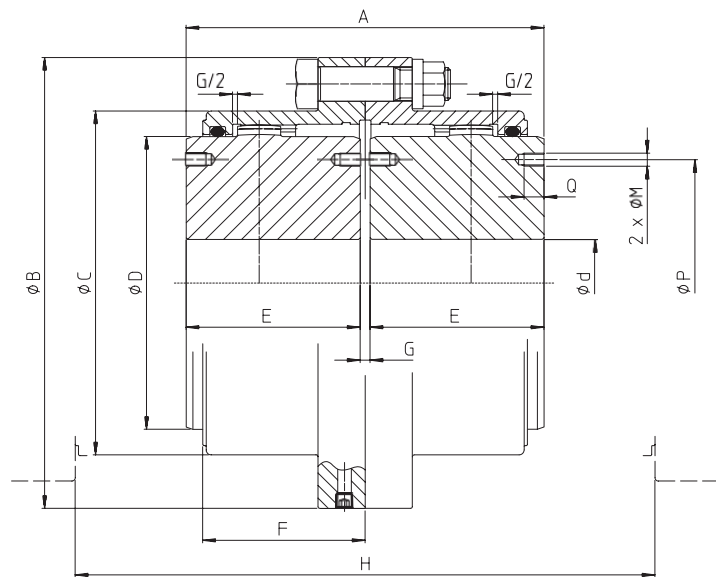

max. 1,5°

*A150			Type FST											
			45	60	75	95	110	130	155	175	195	215	240	275
	1	d nominal max. mm	45	60	75	95	110	130	155	175	195	215	240	275
		d Ømin. mm	0	0	0	0	0	55	65	80	90	100	120	150
		*d Ømax. mm	50	64	78	98	112	132	158	175	198	217	244	275
	2	Tn Nm	1300	2800	5000	10000	16000	22000	32000	45000	62000	84000	115000	174000
		TP	2600	5600	10000	20000	32000	44000	64000	90000	124000	168000	230000	348000
	3.1	tr/min	5000	4400	4000	3600	3350	3100	2800	2700	2550	2450	2300	2150
		omw/min	7000	6200	5650	5100	4700	4350	4000	3800	3600	3450	3300	3050
	-	degré	2x0,75	2x0,75	2x0,75	2x0,75	2x0,75	2x0,75	2x0,75	2x0,75	2x0,75	2x0,75	2x0,75	2x0,75
		graad												
	-	mm: ±	0,35	0,4	0,5	0,6	0,7	0,9	1	1,1	1,2	1,4	1,5	1,7
	4	J (WR ²)	0,005	0,015	0,040	0,105	0,191	0,430	0,842	1,320	2,448	3,716	5,384	10,872
	5	kg	4,1	8,0	14,6	26,1	38,8	59,2	89,4	117,5	167,1	222,4	275,0	413,6
	6	dm ³	0,05	0,07	0,13	0,21	0,36	0,52	0,80	0,98	1,51	2,02	2,43	3,29
mm: ±	A	mm	89	103	127	157	185	216	246	278	308	358	388	450
	B	mm	111	141	171	210	234	274	312	337	380	405	444	506
	C	mm	80	103,5	129,5	156	181	209	247	273	307	338	368	426
	D	mm	67	87	106	130	151	178	213	235	263	286	316	372
	E	mm	43	50	62	76	90	105	120	135	150	175	190	220
	F	mm	41	47	58,5	68,5	82	98	108,5	121	132	151,5	165	183,5
	G	mm	3	3	3	5	5	6	6	8	8	8	8	10
	H	10 mm	147	166	212	249	295	350	392	440	484	562	616	688
	M	mm								M 12	M 16	M 16	M 16	M 20
	P	mm								205	226	250	276	330
O	mm								18	24	24	24	30	

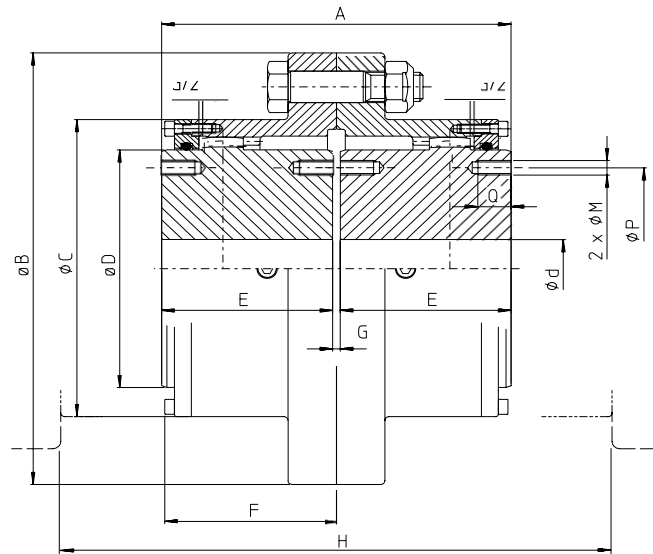

max. 1,5°

*A150		Type FST																	
		280	320	360N	400N	450N	500	530	560	600	660	730	830	900	1000	1060	1130		
	1	mm	280	320	360	400	450	500	530	560	600	660	730	830	900	1000	1060	1130	
		$d \varnothing \text{ min.}$	180	200	220	260	280	300	330	350	380	420	480	540	580	640	680	740	
		$*d \varnothing \text{ max.}$	310	340	375	420	470	500	530	560	600	660	730	830	900	1000	1060	1130	
	2	Nm	Tn	244000	290000	370000	450000	560000	630000	750000	860000	1020000	1290000	2020000	2450000	3070000	3610000	4390000	5040000
			TP	488000	580000	740000	900000	1120000	1260000	1500000	1720000	2040000	2580000	4040000	4900000	6140000	7220000	8780000	10080000
	3	tr/min omw/min rpm min ⁻¹	1900	1800	1500	1400	1300	1150	1050	900	800	550	450	380	325	280	240	220	
	-	degré graad degree Grad	2x0,75	2x0,75	2x0,75	2x0,75	2x0,75	2x0,75	2x0,75	2x0,75	2x0,75	2x0,75	2x0,75	2x0,75	2x0,75	2x0,75	2x0,75	2x0,75	
	-	mm: ±	2	2,1	2,3	2,5	2,7	2,8	3	3,2	3,4	3,6	3,7	4	4,4	4,8	5,2	5,4	
	4	kgm ²	20,1	31	45	68	105	164	228	313	430	685	1161	1756	2580	3690	5090	6730	
	5	kg	591	760	932	1180	1532	1950	2330	2840	3370	4370	6110	7810	9730	11860	14220	16380	
	6	dm ³	6,44	7,6	11	12	16	18	23	25	29	39	57	77	105	130	160	180	
	A	mm	570	597	623	673	713	759	809	859	905	945	1105	1205	1285	1365	1405	1425	
	B	mm	591	640	684	742	804	908	965	1029	1092	1200	1330	1440	1545	1650	1750	1860	
	C	mm	472	518	562	620	682	733	787	841	892	997	1130	1240	1345	1450	1550	1660	
	D	mm	394	432	480	530	594	629	673	724	772	870	965	1062	1156	1254	1346	1448	
	E	mm	280	292	305	330	350	370	395	420	440	460	540	590	630	670	690	700	
	F	mm	225	234	251	269	283	301	318	333	361	375	408	448	483	528	538	548	
	G	mm	10	13	13	13	13	19	19	19	25	25	25	25	25	25	25	25	
	H	mm	632	660	705	745	770	825	870	900	990	1020	1130	1210	1290	1400	1420	1440	
	M	mm	M 20	M 20	M 24	M 24	M 24	M 42	M 42	M 42	M 48	M 48	M 48	M 48	M 48	M 48	M 48	M 48	
	P	mm	336	377	420	480	544	568	600	642	680	765	860	950	1040	1130	1230	1300	
	O	mm	30	30	40	40	40	76	76	76	82	82	82	82	82	82	82	82	

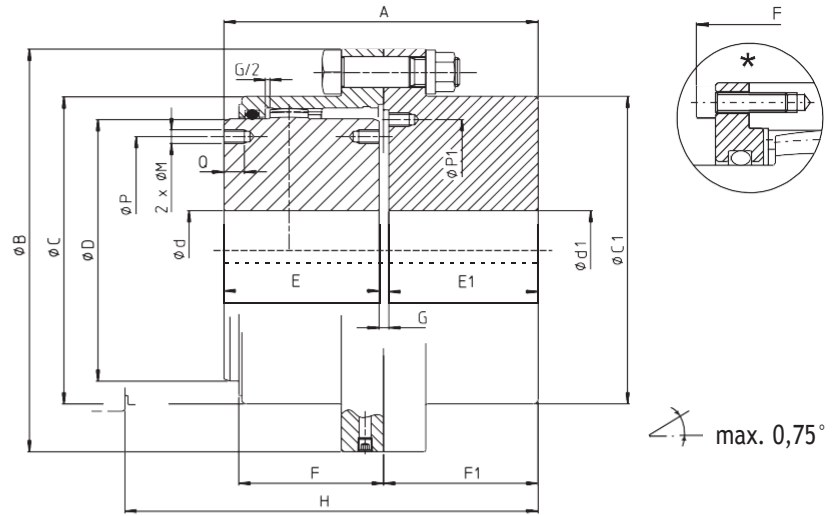
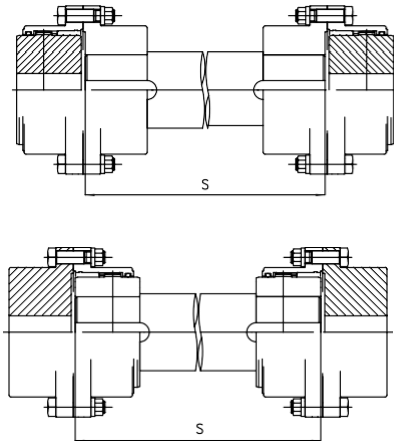

← A150		45	60	75	95	Type FFS										*	*
		110	130	155	175	195	215	240	275	280	320						
	d Ø nominal max.	mm	45	60	75	95	110	130	155	175	195	215	240	275	280	320	
	d Ø min.	mm	0	0	0	0	0	55	65	80	90	100	120	150	180	200	
	*d Ø max.	mm	50	64	78	98	112	132	158	175	198	217	244	290	310	340	
	d1 Ø max.	mm	55	75	95	110	130	155	180	200	230	250	280	330	360	400	
	Ø min.	mm	0	0	0	0	0	55	65	80	90	100	120	150	180	200	
	Tn	Nm	1300	2800	5000	10000	16000	22000	32000	45000	62000	84000	115000	174000	244000	290000	
	Tp	Nm	2600	5600	10000	20000	32000	44000	64000	90000	124000	168000	230000	348000	488000	580000	
	min. max.	tr/min omw/min rpm min ⁻¹															
		degré graad degree Grad	0,75	0,75	0,75	0,75	0,75	0,75	0,75	0,75	0,75	0,75	0,75	0,75	0,75	0,75	
	J (WR ²)	kgm ²	0,005	0,016	0,040	0,107	0,197	0,446	0,868	1,362	2,584	3,900	5,650	11,446	22,6	34,5	
		kg	4,1	8,2	14,6	26,5	39,6	60,3	90,3	119,0	174,3	231,1	285,2	429,3	648	822	
		dm ³	0,023	0,037	0,065	0,104	0,181	0,261	0,398	0,488	0,756	1,009	1,215	1,643	3,2	3,8	
nm: ±	A	mm	88	102	125	156	183	212,5	239,5	272	308	358	390	453	573	598,5	
	B	mm	111	141	171	210	234	274	312	337	380	405	444	506	591	640	
	C	mm	80	103,5	129,5	156	181	209	247	273	307	338	368	426	472	518	
	C1	mm	80	103,5	126	152	178	208	245	270	305	330	362	416			
	D	mm	67	87	106	130	151	178	213	235	263	286	316	372	394	432	
	E	mm	43	50	62	76	90	105	120	135	150	175	190	220	280	292	
	E1	mm	40	47	58	74	87	101	113	129	150	175	190	220	280	292	
	F	mm	41	47	58,5	68,5	82	98	108,5	121	132	151,5	165	183,5	225	234	
	F1	mm	43,5	50,5	61,5	77,5	90,5	104,5	116,5	133	154	179	196	228	288	300	
	G	mm	5	5	5	6	6	6,5	6,5	8	8	8	10	13	13	14,5	
	H	mm	117	133,5	167,5	202	238	279,5	312,5	353	396	460	504	572	606	637	
	M	mm								M 12	M 16	M 16	M 16	M 20	M 20	M 20	
	P	mm								205	226	250	276	330	336	377	
P1	mm								235	265	290	320	370	416	456		
Q	mm								18	24	24	24	30	30	30		

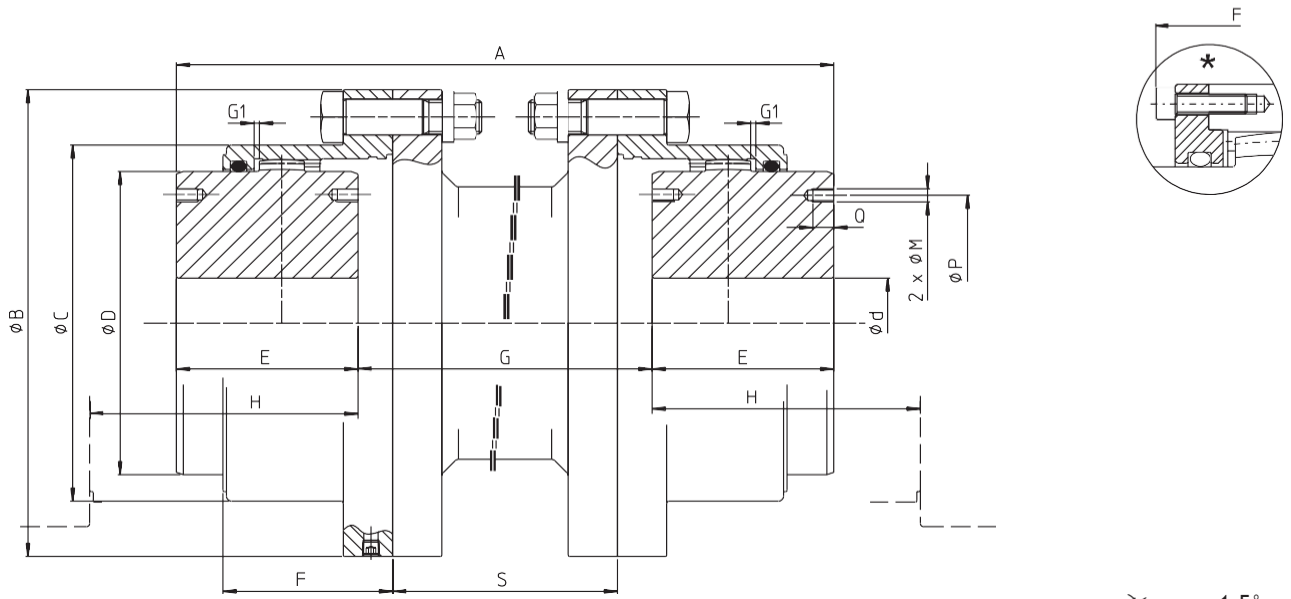

max. 1,5°

←A150			Type FSE														
			45	60	75	95	110	130	155	175	195	215	240	275	* 280	* 320	
	1	d nominal max. mm	45	60	75	95	110	130	155	175	195	215	240	275	280	320	
		d Ø min. mm	0	0	0	0	0	55	65	80	90	100	120	150	180	200	
		* d Ø max. mm	50	64	78	98	112	132	158	175	198	217	244	290	310	340	
	2	Nm	Tn	1300	2800	5000	10000	16000	22000	32000	45000	62000	84000	115000	174000	244000	290000
			1m Tp	2600	5600	10000	20000	32000	44000	64000	90000	124000	168000	230000	348000	488000	580000
	3.3	tr/min omw/min rpm min ⁻¹															
	-	degré graad degree Grad	2x0,75	2x0,75	2x0,75	2x0,75	2x0,75	2x0,75	2x0,75	2x0,75	2x0,75	2x0,75	2x0,75	2x0,75	2x0,75	2x0,75	
	4.1	kgm ²															
	5.1	kg															
	6	dm ³	2x0,025	2x0,037	2x0,065	2x0,105	2x0,18	2x0,26	2x0,40	2x0,49	2x0,76	2x1,01	2x1,21	2x1,64	2x3,2	2x3,8	
min.	A 8	mm	167	195	245	291	323	380	412	450	516	580	624	676	780	827	
	B	mm	111	141	171	210	234	274	312	337	380	405	444	506	591	640	
mm: ±	C	mm	80	103,5	129,5	156	181	209	247	273	307	338	368	426	472	518	
	D	mm	67	87	106	130	151	178	213	235	263	286	316	372	394	432	
min.	E	mm	43	50	62	76	90	105	120	135	150	175	190	220	280	292	
	F	mm	41	47	58,5	68,5	82	98	108,5	121	132	151,5	165	183,5	225	234	
min.	G 8	mm	81	95	121	139	143	170	172	180	216	230	244	236	226	243	
	H 10	mm	63	76	91	110	131	155	175	195	214	246	266	306	305	320	
min	M	mm								M 12	M 16	M 16	M 16	M 20	M 20	M 20	
	P	mm								205	226	250	276	330	336	377	
	Q	mm								18	24	24	24	30	30	30	
	S 8	mm	60	80	90	110	110	130	130	130	160	160	160	160	176	190	
	G1	mm	1,5	1,5	1,5	2,5	2,5	3	3	4	4	4	4	5	5	6,5	

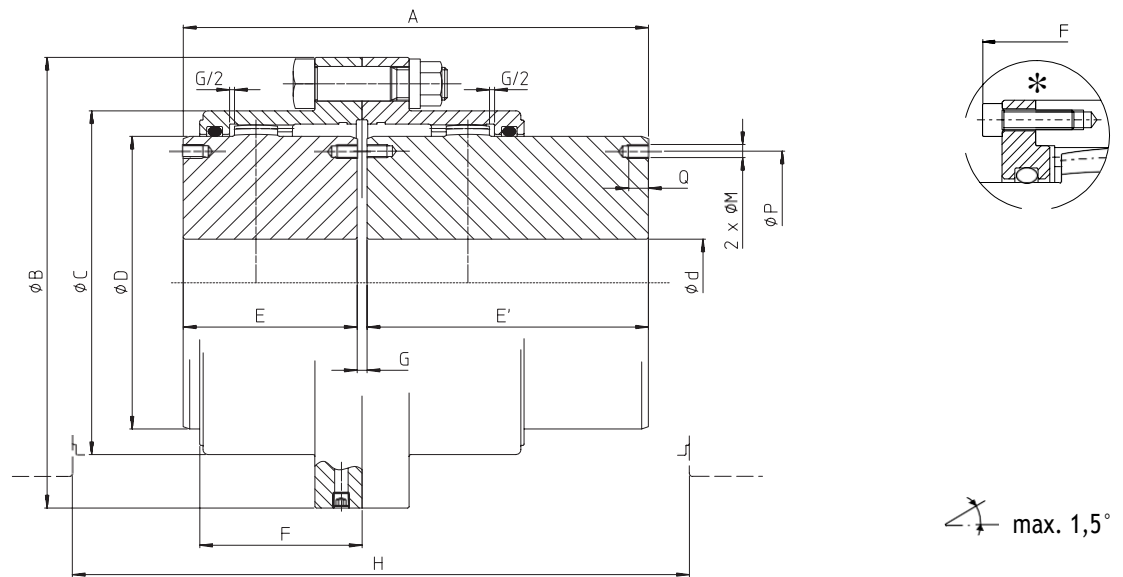

*A150			45	60	75	95	110	130	Type FMM		155	175	195	215	240	275	* 280	* 320			
	d	nominal max.	mm	45	60	75	95	110	130	155	175	195	215	240	275	280	320				
		min.	mm	0	0	0	0	0	55	65	80	90	100	120	150	180	200				
		max.	mm	50	64	78	98	112	132	158	175	198	217	244	290	310	340				
	Tn	Tp	Nm	1300	2800	5000	10000	1600	22000	32000	45000	62000	84000	115000	174000	244000	290000				
				2600	5600	10000	20000	0	44000	64000	90000	124000	168000	230000	348000	488000	580000				
	min.	max.	rpm	5000	4400	4000	3600	32000	3100	2800	2700	2550	2450	2300	2150	1900	1800				
				7000	6200	5650	5100	3350	4350	4000	3800	3600	3450	3300	3050	2950	2800				
	-	-	degré	2x0,7	2x0,75	2x0,75	2x0,7	2x0,7	2x0,7	2x0,7	2x0,7	2x0,75	2x0,75	2x0,75	2x0,75	2x0,75	2x0,75	2x0,75			
				5	5	5	5	5	5	5	5	5	5	5	5	5	5	5	5	5	
	-	-	mm: ±	0,35	0,4	0,5	0,6	0,7	0,9	1	1,1	1,2	1,4	1,5	1,7	2	2,1				
				0,005	0,018	0,047	0,121	0,221	0,480	0,953	1,47	2,71	4,10	6,07	12,79	22,4	35,6				
	5	-	kg	5,1	11,0	19,3	33,4	49,3	70,7	107	137	193	256	322	506	689	920				
				0,05	0,07	0,13	0,21	0,36	0,52	0,80	0,98	1,51	2,02	2,43	3,29	6,44	7,6				
mm: ±	10	-	dm³	0,05	0,07	0,13	0,21	0,36	0,52	0,80	0,98	1,51	2,02	2,43	3,29	6,44	7,6				
				A	mm		167	195						378	433	478	580	700	775		
				B	mm	126	141	171	227		281	316	343	380	405	444	506	591	640		
				C	mm	111	103,5	129,5	210	260	274	312	337	307	338	368	426	472	518		
				D	mm	80	87	106	156	234	209	247	273	263	286	316	372	394	432		
				E	mm	67	50	62	130	181	178	213	235	150	175	190	220	280	292		
				E'	mm	43	114	130	76	151	105	120	135	220	250	280	350	410	470		
				F	mm	80	47	58,5	146	90	170	190	200	132	151,5	165	183,5	225	234		
				G	mm	41	3	3	68,5	165	98	108,5	121	8	8	8	10	10	13		
				H	mm	3	200	239	5	82	6	6	8	484	562	616	704	765	805		
				M	mm	157			276	5	351	392	440	M 16	M 16	M 16	M 20	M 20	M 20		
				P	mm					318			M 12	226	250	276	330	336	377		
				Q	mm								205	24	24	24	30	30	30		

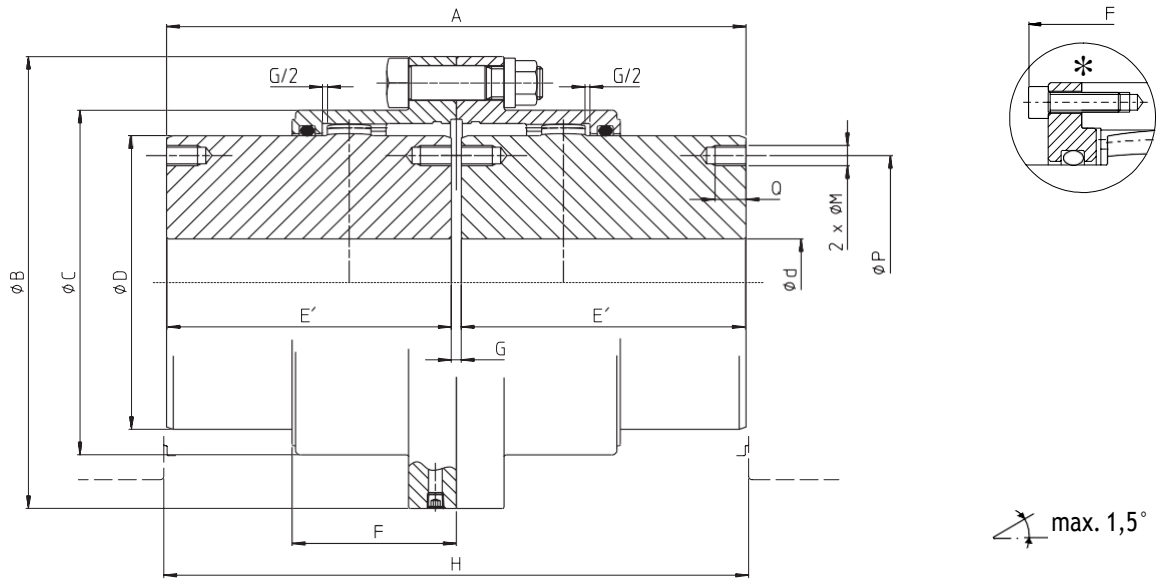



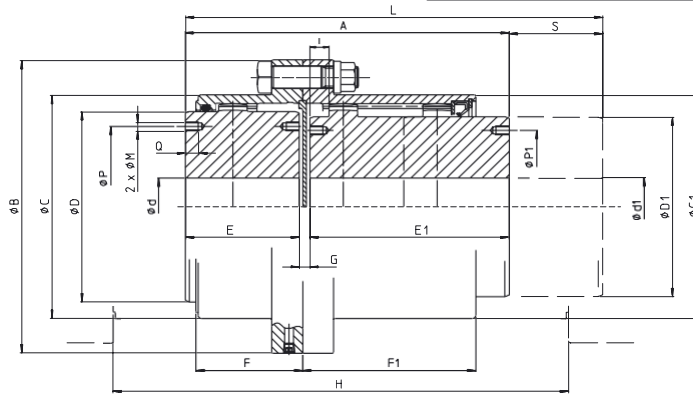

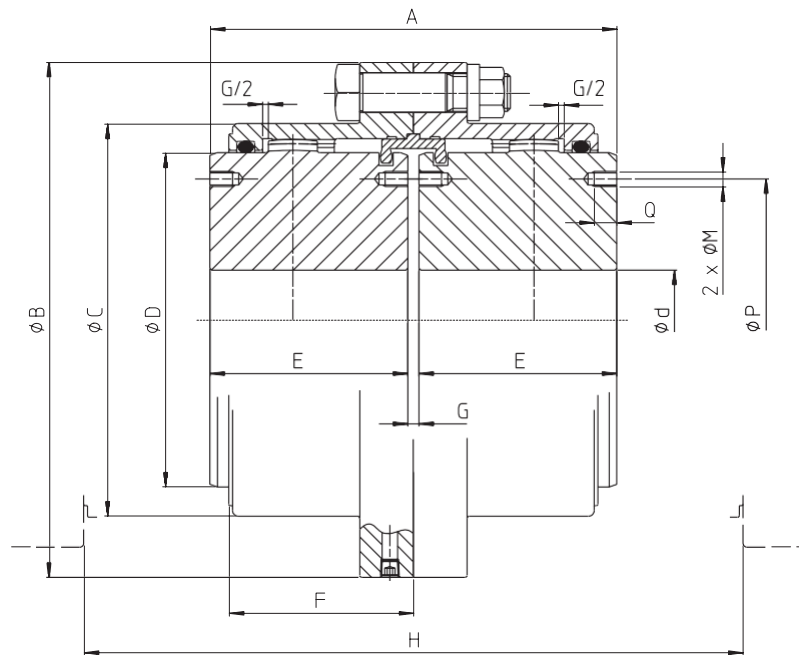

*A150		45	60	75	95	110	130	Type	FDM	195	215	240	275	* 280	* 320	
	n							155	175							
	d	mm	45	60	75	95	110	130	155	175	195	215	240	275	280	320
	d	mm	0	0	0	0	55	65	80	90	100	120	150	180	200	
	d'	mm	50	64	78	98	112	132	158	175	198	217	244	290	310	340
	Tn	Nm	1300	2800	5000	10000	16000	22000	32000	45000	62000	84000	115000	174000	244000	290000
	Tp	Nm	2600	5600	10000	20000	32000	44000	64000	90000	124000	168000	230000	348000	488000	580000
	3.1	tr/min	5000	4400	4000	3600	3350	3100	2800	2700	2550	2450	2300	2150	1900	1800
	3.2	omw/min	7000	6200	5650	5100	4700	4350	4000	3800	3600	3450	3300	3050	2950	2800
	—	degré	2x0,75	2x0,75	2x0,75	2x0,75	2x0,75	2x0,75	2x0,75	2x0,75	2x0,75	2x0,75	2x0,75	2x0,75	2x0,75	2x0,75
	—	grad														
	—	mm: ±	0,35	0,4	0,5	0,6	0,7	0,9	1	1,1	1,2	1,4	1,5	1,7	2	2,1
	—	mm: ±														
	4	kgm²	0,006	0,021	0,053	0,136	0,251	0,530	1,06	1,62	2,96	4,49	6,76	14,70	24,7	40,2
	—	kgm²														
	5	kg	6,1	14,0	24,0	40,7	59,9	82,1	125	157	220	289	370	599	787	1080
	—	kg														
	6	dm³	0,05	0,07	0,13	0,21	0,36	0,52	0,80	0,98	1,51	2,02	2,43	3,29	6,44	7,6
	—	dm³														
	A	mm	163	231	263	297	335	346	386	408	448	508	568	710	830	953
	B	mm	111	141	171	210	234	274	312	337	380	405	444	506	591	640
	C	mm	80	103,5	129,5	156	181	209	247	273	307	338	368	426	472	518
	D	mm	67	87	106	130	151	178	213	235	263	286	316	372	394	432
	E'	mm	80	114	130	146	165	170	190	200	220	250	280	350	410	470
	F	mm	41	47	58,5	68,5	82	98	108,5	121	132	151,5	165	183,5	225	234
	G	mm	3	3	3	5	5	6	6	8	8	8	8	10	10	13
	H	mm	163	231	263	297	335	350	392	440	484	562	616	710	895	935
	M	mm								M12	M16	M16	M16	M20	M20	M20
	P	mm									205	226	250	276	330	336
	Q	mm									18	24	24	30	30	30
		mm														



				Type FSH								
				60	75	95	110	130	155	175	195	215
	d Ø nominal max.	1	mm	60	75	95	110	130	155	175	195	215
	d Ø min.	1	mm	0	0	0	0	55	65	80	90	100
	+d Ø max	1	mm	64	78	98	112	132	158	175	198	217
	d1 Ø max.	1	mm	0	0	0	0	55	65	80	90	100
	Ø min.	1	mm	55	70	85	100	120	140	170	190	210
	Tn	2	Nm	2800	5000	10000	16000	22000	32000	45000	62000	84000
	Tp	2	Nm	5600	10000	20000	32000	44000	64000	90000	124000	168000
	3.3	tr/min omw/min rpm min ⁻¹										
	4.1	degré graad degree Grad										
	4.1	J (WR ²)	kgm ²									
	5.1	kg										
	6.1	dm ³										
max.	A	6.1	mm	193	210	231	250	276	291	319	344	381
	B		mm	141	171	210	234	274	312	337	380	405
	C		mm	103,5	129,5	156	181	209	247	273	307	338
	C1		mm	108	129,5	156	181	209	247	270	305	330
	D		mm	87	106	130	151	178	213	235	263	286
	D1		mm	78	98	115	140	165	195	230	260	280
	E		mm	50	62	76	90	105	120	135	150	175
	E1	6.1	mm	135	140	145	150	160	160	170	180	190
max.	F		mm	47	58,5	68,5	82	98	108,5	121	132	151,5
max.	F1	6.1	mm	138	139	144	157	159	162	168	168	179
min.	G	min	mm	8	8	10	10	11	11	14	14	16
max.	H	10	mm	247	276	300	330	370	385	425	460	510
	I		mm	10	10	10	10	10	15	15	15	15
max.	L	6.1	mm	278	290	311	340	361	371	394	414	451
	M		mm							M12	M 12	M 16
	P		mm							205	226	250
	P ₁		mm							200	225	245
	Q		mm							18	18	24
max.	S	7	mm	85	80	80	90	85	80	75	70	70



 max.
 NOUS CONSULTER
 ONS RAADPLEGEN
 REFER TO FACTORY
 AUF ANFRAGE

*A150			Type FLE												
			45	60	75	95	110	130	155	175	195	215	240	275	
	1	d Ø nominal max.	45	60	75	95	110	130	155	175	195	215	240	275	
		d Ø min.	0	0	0	0	0	55	65	80	90	100	120	150	
		* d Ø max	50	64	78	98	112	132	158	175	198	217	244	290	
	2	Tn	1300	2800	5000	10000	16000	22000	32000	45000	62000	84000	115000	174000	
		Tp	2600	5600	10000	20000	32000	44000	64000	90000	124000	168000	230000	348000	
	3.1	tr/min	5000	4400	4000	3600	3350	3100	2800	2700	25550	2450	2300	2150	
		omw/min	7000	6200	5650	5100	4700	4350	4000	3800	3600	3450	3300	3050	
	4	min.max.	0,005	0,015	0,040	0,105	0,191	0,430	0,842	1,32	2,45	3,72	5,38	10,87	
		J (WR ²)													
	5	kg	4,1	8,0	14,6	26,1	38,8	59,2	89,4	118	167	222	275	414	
		dm ³	2x0,025	2x0,037	2x0,065	2x0,105	2x0,18	2x0,26	2x0,40	2x0,49	2x0,76	2x1,01	2x1,21	2x1,64	
	6	A	89	103	127	157	185	216	246	278	308	358	388	450	
		B	117	141	171	210	234	274	312	337	380	405	444	506	
		C	80	103,5	129,5	156	181	209	247	273	307	338	368	426	
		D	67	87	106	130	151	178	213	235	263	286	316	372	
		E	43	50	62	76	90	105	120	135	150	175	190	220	
		F	41	47	58,5	68,5	82	98	108,5	121	132	151,5	165	183,5	
		G	3	3	3	5	5	6	6	8	8	8	8	10	
		H	10	147	166	212	249	295	350	392	440	484	562	616	688
		M									M 12	M 16	M 16	M 16	M 20
		P									205	226	250	276	330
		Q									18	24	24	24	30

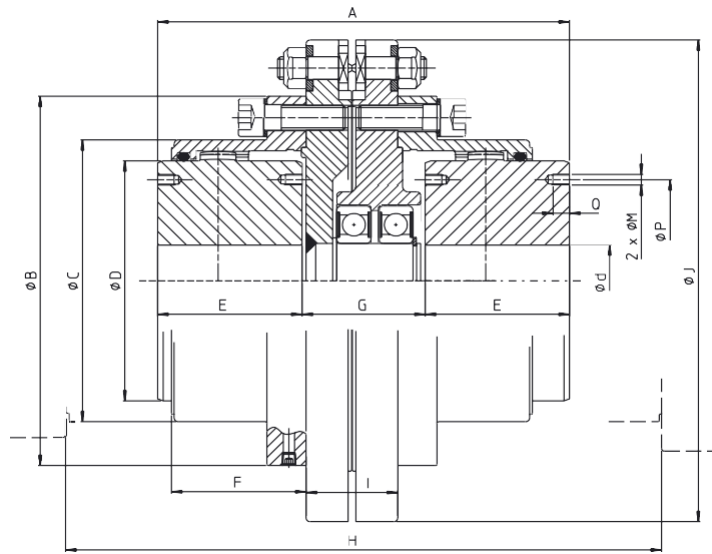

max. 1,5°

←A150			Type FSP												
			45	60	75	95	110	130	155	175	195	215	240	275	
	1	d nominal max. mm	45	60	75	95	110	130	155	175	195	215	240	275	
		d ø min. mm	0	0	0	0	0	55	65	80	90	100	120	150	
		*d ø max. mm	50	64	78	98	112	132	158	175	198	217	244	290	
	2	Tn Nm	750	1800	3500	7000	11000	15500	22000	31500	43500	55000	81000	122500	
		TP Nm	1500	3600	7000	14000	22000	31000	44000	63000	87000	110000	162000	245000	
	3.1	tr/min omw/min rpm min ⁻¹	4000	3600	3300	2950	2550	2150	2000	1800	1650	1450	1400	1350	
	-	degré graad degree Grad	2x0,75	2x0,75	2x0,75	2x0,75	2x0,75	2x0,75	2x0,75	2x0,75	2x0,75	2x0,75	2x0,75	2x0,75	
	-	mm: ±	0,6	0,7	0,8	0,9	1	1,2	1,3	1,4	1,5	1,9	2,0	2,3	
	4	J (WR ²)	0,019	0,055	0,098	0,272	0,448	1,01	1,75	2,77	4,61	6,82	9,68	18,4	
	5	kg	8,5	16,9	26,5	45,1	62,5	99,5	139	183	247	316	395	579	
	6	dm ³	2x0,025	2x0,037	2x0,065	2x0,105	2x0,18	2x0,26	2x0,40	2x0,49	2x0,76	2x1,01	2x1,21	2x1,64	
mm: ±	A	mm	131	153	185	217	247	293	324	363	396	467	504	579	
	B	mm	111	141	171	210	234	274	312	337	380	405	444	506	
	C	mm	80	103,5	129,5	156	181	209	247	273	307	338	368	426	
	D	mm	67	87	106	130	151	178	213	235	263	286	316	372	
	E	mm	43	50	62	76	90	105	120	135	150	175	190	220	
	F	mm	41	47	58,5	68,5	82	98	108,5	121	132	151,5	165	183,5	
	G	9	mm	45	53	61	65	67	83	84	93	96	117	124	139
	H	10	mm	189	216	270	309	357	427	470	525	572	671	732	817
	I	mm	33	44	44	48	48	60	60	64	64	78	78	96	
	J	mm	155	194	228	267	300	358	384	428	470	524	560	656	
	M	mm								M 12	M 16	M 16	M 16	M 20	
	P	mm								205	226	250	276	330	
	Q	mm								18	24	24	24	30	

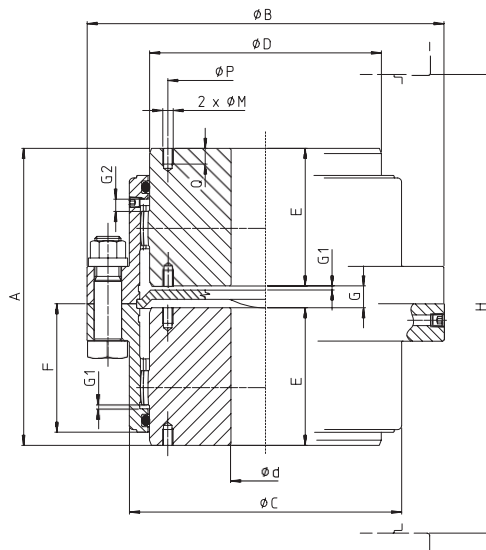

max. 1,5°

La cote G ne peut varier en cours de fonctionnement
Maat G mag niet gewijzigd worden bij werking
Distance G may not vary during operation
Das Maß "G" muß während des Betriebs konstant bleiben

*A150			Type FSV												
			45	60	75	95	110	130	155	175	195	215	240	275	
 d Ø nominal max. d Ø min. * d Ø max.	1	mm	45	60	75	95	110	130	155	175	195	215	240	275	
		mm	0	0	0	0	0	55	65	80	90	100	120	150	
		mm	50	64	78	98	112	132	158	175	198	217	244	290	
 1m Tn Tp	2	Nm	1300	2800	5000	10000	16000	22000	32000	45000	62000	84000	115000	174000	
			2600	5600	10000	20000	32000	44000	64000	90000	124000	168000	230000	348000	
 /min.max.	3	tr/min omw/min rpm min ⁻¹	5000	4400	4000	3600	3350	3100	2800	2700	2550	2450	2300	2150	
 α	—	degré graad degree Grad	2x0,75	2x0,75	2x0,75	2x0,75	2x0,75	2x0,75	2x0,75	2x0,75	2x0,75	2x0,5	2x0,5	2x0,5	
	—	mm: ±	0,35	0,4	0,5	0,6	0,7	0,9	1	1,1	1,2	0,9	1	1,1	
 J (WR ²)	4	kgm ²	0,005	0,015	0,040	0,105	0,191	0,430	0,842	1,32	2,45	3,72	5,38	10,9	
	5	kg	4,1	8,0	14,6	26,1	38,8	59,2	89,4	118	167	222	275	414	
 Grease	6	dm ³	2x0,021	2x0,037	2x0,057	2x0,104	2x0,164	2x0,254	2x0,387	2x0,514	2x0,741	2x0,940	2x1,12	2x1,69	
mm: ±	A	mm	94	105	136,5	163	193	224	255	287	320	377	414	468	
	B	mm	111	141	171	210	234	274	312	337	380	405	444	506	
	C	mm	80	103,5	129,5	156	181	209	247	273	307	338	368	426	
	D	mm	67	87	106	130	151	178	213	235	263	286	316	372	
	E	mm	43	50	62	76	90	105	120	135	150	175	190	220	
	F	mm	41	47	58,5	68,5	82	98	108,5	121	132	151,5	165	183,5	
	G	9	mm	8	5	12,5	11	13	14	15	17	20	27	34	28
	G1	9	mm	1,5	1,5	1,5	2,5	2,5	3	3	4	4	4	4	5
	G2	9	mm	5,5	5,5	6	8,5	8,5	12	12	16	16	16	16	20
	H	10	mm	147	166	212	249	295	350	392	440	484	562	616	688
	M		mm								M 12	M 16	M 16	M 16	M 20
	P		mm								205	226	250	276	330
	Q		mm								18	24	24	24	30

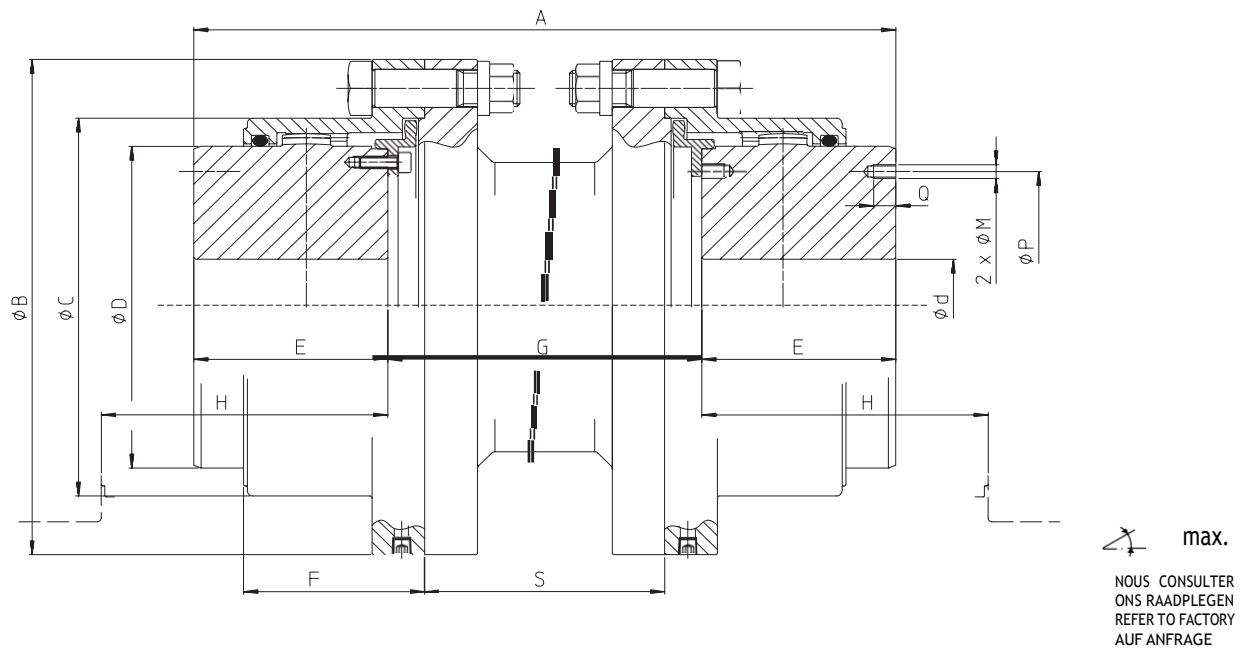

*A150			Type FSLE												
			45	60	75	95	110	130	155	175	195	215	240	275	
	1	mm	45	60	75	95	110	130	155	175	195	215	240	275	
		mm	0	0	0	0	0	55	65	80	90	100	120	150	
		mm	50	64	78	98	112	132	158	175	198	217	244	290	
	2	Tn	130	2800	5000	1000	1600	22000	32000	45000	62000	8400	11500	17400	
		TP	2600	5600	10000	20000	32000	44000	64000	90000	124000	168000	230000	348000	
	3.3	tr/min													
		omw/min													
	4.1	kgm²													
	5.1	kg													
	6	dm³	2x0,025	2x0,037	2x0,065	2x0,105	2x0,18	2x0,26	2x0,40	2x0,49	2x0,76	2x1,01	2x1,21	2x1,64	
mini mm: ± mini	A	mm	167	195	245	291	323	380	412	450	516	580	624	676	
	B	mm	111	141	171	210	234	274	312	337	380	405	444	506	
	C	mm	80	103,5	129,5	156	181	209	247	273	307	338	368	426	
	D	mm	67	87	106	130	151	178	213	235	263	286	316	372	
	E	mm	43	50	62	76	90	105	120	135	150	175	190	220	
	F	mm	41	47	58,5	68,5	82	98	108,5	121	132	151,5	165	183,5	
	G	8	mm	81	95	121	139	143	170	172	180	216	230	244	236
	G1		mm	1,5	1,5	1,5	2,5	2,5	3	3	4	4	4	4	5
	H	10	mm	63	76	91	110	131	155	175	195	214	246	266	306
	M		mm								M 12	M 16	M 16	M 16	M 20
mini	P	mm								205	226	250	276	330	
	Q	mm								18	24	24	24	30	
	S	8	mm	60	80	90	110	110	130	130	130	10	160	160	

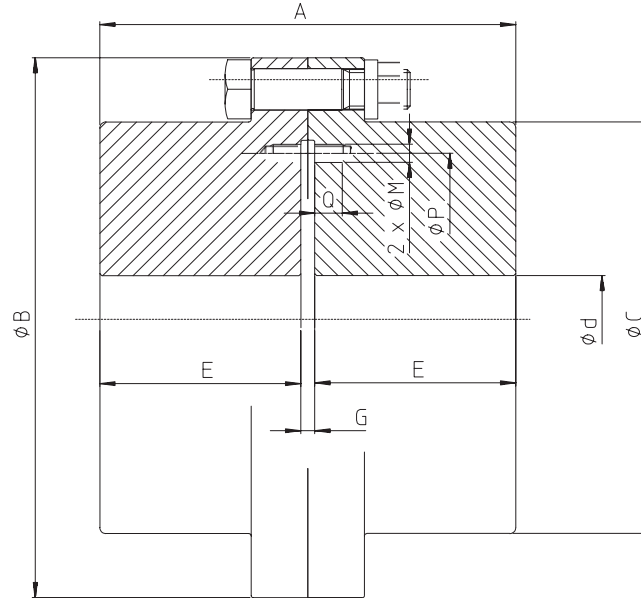







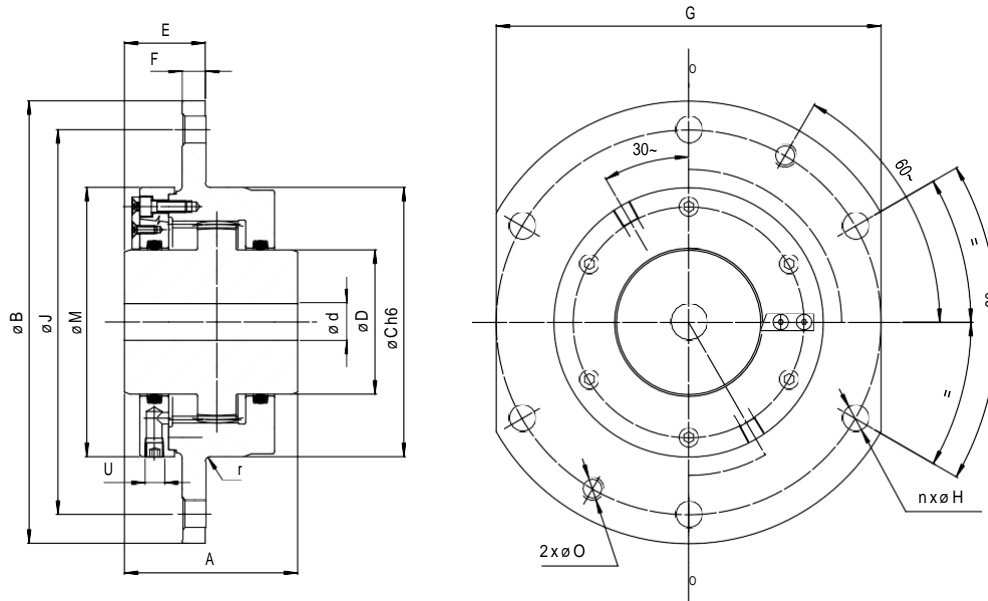

*A150			Type FRR											
			45	60	75	95	110	130	155	175	195	215	240	275
	1	d Ø max.	55	75	95	110	130	155	180	200	230	250	280	330
		d Ø min.	0	0	0	0	0	55	65	80	90	100	120	150
	2	Tn	1300	2800	5000	10000	16000	22000	32000	45000	62000	84000	115000	174000
		Tp	2600	5600	10000	20000	32000	44000	64000	90000	124000	168000	230000	348000
	3.3	tr/min omw/min rpm min ⁻¹	6000	5500	5000	4400	4000	3500	3000	2700	2500	2200	2100	2000
	4	J (WR ²)	0,005	0,017	0,041	0,109	0,203	0,459	0,9	1,4	2,7	4,1	6,0	12,0
	5.1	kg	4,4	8,4	14,6	26,9	40,4	62,2	92,1	123	185	244	308	461
mini	A	mm	87	101	123	155	181	209	233	266	308	358	392	456
	B	mm	111	141	171	210	234	274	312	337	380	405	444	506
	C	mm	80	103,5	126	152	178	208	245	270	305	330	362	416
	E	mm	40	47	58	74	87	101	113	129	150	175	190	220
	G	mm	7	7	7	7	7	7	7	8	8	8	12	16
	M	mm								M 12	M 16	M 16	M 16	M 20
	P	mm								235	265	290	320	370
	Q	mm								18	24	24	24	30



FWD 150 ⇨ 420



 ←A150	ESCO	150	170	220	250	280	300	320	380	420		
	SEB	SG130	SG140	SG185	SG200	SG240	SG270	SG315	SG355	SG400		
 ø max. ø min.	1	mm	150	170	220	250	280	300	320	380	420	
		mm	65	80	120	150	180	190	200	220	260	
 1m Nm	Tn	2	kNm	37	62	130	160	310	385	500	660	800
	Tp			74	124	260	320	620	770	1000	1320	1600
RADIAL LOAD	-	kN	88	112	188	221	314	343	399	499	587	
 ΔK _w	-	degré graad degree Grad	0,75	0,75	0,75	0,75	0,75	0,75	0,75	0,75	0,75	
 ΔK _a	-	mm: ±	7	8	8	8	8	8	10	10	10	
 J (WR ²)	4	kgm ²	0,78	1,69	4,7	6,4	13,6	18,1	25,2	42,2	62	
	5	kg	69	105	198	235	370	460	560	760	940	
 Grease	6	dm ³	0,20	0,39	0,54	0,59	0,91	1,17	1,83	1,98	2,41	
mm: ±	A	mm	170	185	240	260	315	350	380	410	450	
	B	mm	400	450	550	580	650	680	710	780	850	
	C	mm	280	340	420	450	530	560	600	670	730	
	D	mm	220	240	320	350	410	440	470	536	580	
	E	mm	45	60	60	60	65	65	81	81	81	
	F	mm	15	20	20	20	25	25	35	35	35	
	G	mm	360	400	500	530	580	600	640	700	760	
	H	mm	19	24	24	24	24	24	28	28	28	
	J	mm	360	400	500	530	600	630	660	730	800	
	M	mm	279	339	419	449	529	559	599	669	729	
	O	mm	M 16	M 20	M 20	M 20	M 20	M 20	M 20	M 20	M 20	
	n	-		10	10	10	14	14	26	26	26	26
	r	mm	2,5	2,5	2,5	2,5	2,5	4	4	4	4	
	u	R"		1/8	1/4	1/4	1/4	1/4	1/4	1/4	1/4	1/4



FET 60 → 275

TORQUE CONTROL DEVICES

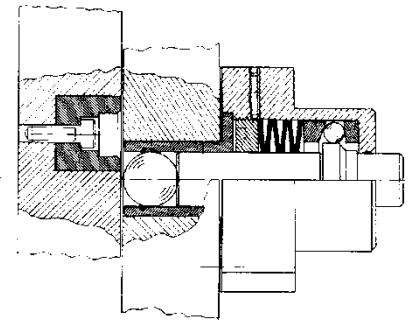
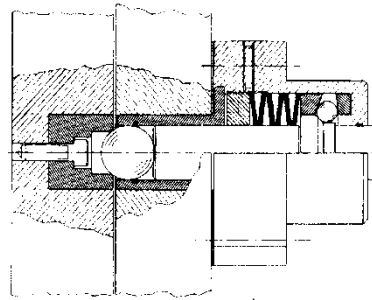
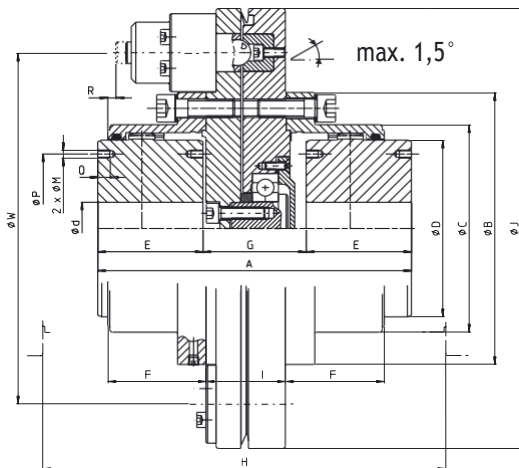

engagé - eingeschaltet - engaged

désengagé - ausgeschaltet - disengaged

		Type FET												
			60/1	75/1	95/2	110/2	130/3	155/3	175/4	195/4	215/5	240/5	275/6	
	d Ø nominal max.	mm	60	75	95	110	130	155	175	195	215	240	275	
	d Ø min.	mm	0	0	0	0	55	65	80	90	100	120	150	
	*d Ø max.	mm	64	78	98	112	132	158	175	198	217	244	290	
	Tn	2	2800	5000	10000	16000	22000	32000	45000	62000	84000	115000	174000	
	TR	min.	Nm	1010	1010	1930	1930	7140	7140	11320	11320	34900	34900	57600
		max.		5600	8180	15600	15600	44000	57200	90000	90750	168000	230000	348000
	min.max.	3	tr/min omw/min rpm min ⁻¹	3600	3300	2950	2550	2150	2000	1800	1650	1400	1350	
		-	degré graad degree Grad	2x0,7 5	2x0,7 5	2x0,7 5	2x0,7 5	2x0,7 5	2x0,7 5	2x0,7 5	2x0,7 5	2x0,7 5	2x0,7 5	
		-	mm: ±	0,7	0,8	1	1,1	1,4	1,5	1,7	1,8	2,2	2,3	2,7
	J (WR ²)	4	kgm ²	0,271	0,323	0,733	0,862	3,84	4,59	7,83	9,28	26,4	31,6	58,9
		5	kg	33,1	41,6	67,9	82,5	184	222	290	345	587	681	1017
	Grease	6	dm ³	2x0,037	2x0,065	2x0,105	2x0,18	2x0,26	2x0,40	2x0,49	2x0,76	2x1,01	2x1,21	2x1,64
mm: ±	A		mm	161	193	228	258	325	356	391	424	512	549	630
	B		mm	141	171	210	234	274	312	337	380	405	444	506
	C		mm	103,5	129,5	156	181	209	247	273	307	338	368	426
	D		mm	87	106	130	151	178	213	235	263	286	316	372
	E		mm	50	62	76	90	105	120	135	150	175	190	220
	F		mm	47	58,5	68,5	82	98	108,5	121	132	151,5	165	183,5
	G		mm	61	69	76	78	115	116	121	124	162	169	190
	H	10	mm	224	278	320	368	459	502	553	600	716	777	868
	I		mm	52	52	59	89	92	92	92	92	123	123	147
	J		mm	288	288	350	350	464	464	538	538	706	706	844
	M		mm							M 12	M 16	M 16	M 16	M 20
	P		mm							205	226	250	276	330
	Q		mm							18	24	24	24	30
	R		mm	-9,5	1	16	28,5	13	20,5	35	45	12,5	37	80,5
W		mm	230	230	292	292	390	390	464	464	582	582	720	



Caractéristiques principales – Voornaamste karakteristieken – Main features – Viktiga fördelar
 Charakteristische Hauptmerkmale – Características principales – Caratteristiche principali

- 3 POSITIONS MOYEURX
- 3 NAVENPOSITIES
- 3 HUBS POSITIONS
- 3 EINBAUMÖGLICHKEITEN
- 3 NAVKOMBINATIONER
- 3 POSICIONES CUBO
- 3 POSIZIONI DEI MOZZI

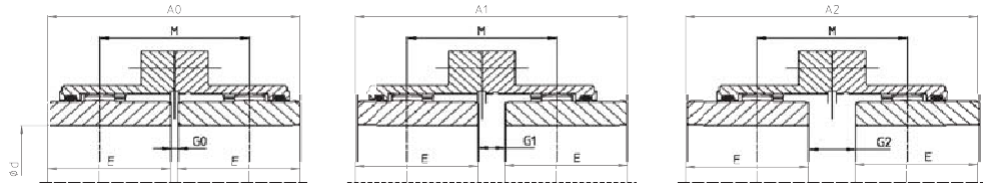

←A105		Type FST																
						110	130	155	175	195	215	240	275	280	320	360N	400N	450N
	d ∅ nominal max. mm	45	60	75	95	110	130	155	175	195	215	240	275	280	320	360	400	450
	d ∅ min. mm	0	0	0	0	0	55	65	80	90	100	120	150	180	200	220	260	280
	*d ∅ max. mm	50	65	78	98	112	132	158	175	198	212	244	290	310	340	390	435	485
	A ₀ mm	89	103	127	157	185	216	246	278	308	358	388	450	570	597	623	673	713
	A ₁ mm	98	109	141	169	199	233	264	299	332	389	426	483	590	617	658	713	761
	A ₂ mm	107	115	155	181	213	250	282	320	356	420	464	516	610	637	693	753	809
	E mm	43	50	62	76	90	105	120	135	150	175	190	220	280	292	305	330	350
	G ₀ mm	3	3	3	5	5	6	6	8	8	8	8	10	10	13	13	13	13
	G ₁ mm	12	9	17	17	19	23	24	29	32	39	46	43	30	33	48	53	61
	G ₂ mm	21	15	31	29	33	40	42	50	56	70	84	76	50	53	83	93	109
	M mm	55	59	79	93	109	128	144	164	182	214	236	263	310	325	353	383	411

*Consult us

4 ALTERNATIVES – 4 ALTERNATIEVEN – 4 ALTERNATIV – 4 AUSFUEHRUNGEN – 4 ALTERNATIVAS – 4 ALTERNATIVE

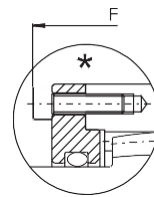
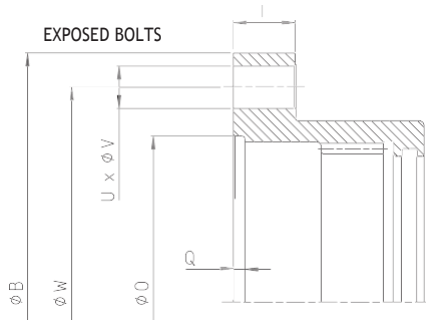
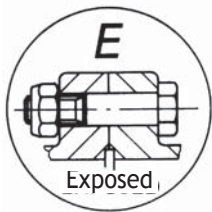

Type →		(1)	(1 1/2)	(2)	(2 1/2)	(3)	(3 1/2)	(4)	(4 1/2)	(5)	(5 1/2)	(6)	(7)	(8)*	*	*	*	*
		45	60	75	95	110	130	155	175	195	215	240	275	280	320	360N	400N	450N
Flange Connection	B mm	111	141	171	210	234	274	312	337	380	405	444	506	591	640	684	742	804
	O mm	78	100	120	144	170	198	234	256	290	315	345	400	451	483	540	590	660
	Q mm	3,5	3,5	3,5	3,5	3,5	3,5	3,5	4	4	4	6	8	8	8	8	10	10
	T mm	14	19	19	22	22	28,5	28,5	28,5	38	38	26	28,5	33	38	38	38	38
Exposed Metric (E.M.)	U Qty.	6	8	6	6	8	8	8	10	10	14	14	16	14	18	24	28	30
	V mm	9	11	13	17	17	21	21	21	21	21	25	25	32	32	32	32	32
	W mm	96	122	150	184	208	242	280	305	345	368	406	460	530	580	624	682	744
Exposed Inch (E.I.)	U Qty.	6	8	6	6	8	8	8	10	8	14	14	16	16				
	V inch.	0,250	0,375	0,500	0,625	0,625	0,750	0,750	0,750	0,875	0,875	0,875	1,000	1,125				
	W inch.	3,750	4,812	5,875	7,125	8,125	9,5	11	12	13,5	14,5	15,75	18,25	20,75				